

WELCON

Servo Drive

Hardware Manual



WER-D048/10-FS00FD-C

welcon
SYSTEMS



Precautions

- Please read this manual carefully before installing and commissioning.
- WELCON SYSTEMS assumes no responsibility whatsoever for any loss or damage arising out of use for any purpose.

Copyright Notice

© 2021 WELCON Systems. All rights reserved.

Copyright in this document is reserved exclusively by WELCON SYSTEMS. That is, the owner of the text, images, and all other materials listed in this document is WELCON SYSTEMS. Therefore, the unauthorized distribution, transfer, or duplication of the text, images, and other materials in this document without the written permission of the copyright holder, WELCON SYSTEMS, is prohibited.

Product Code for welcon Drive

WER-D024/05-FSxxxx-E

Product Type

- WE** WELCON Standard
- **** User Code (only for customized order)

Drive Shape

- R** Rectangle Type Board
- C** Circle Type Board
- M** Miniature Board

Power

- D** DC
- A** AC

Voltage

- 024** 24V(DC)
- 048** 48V(DC)
- 220** 220V(AC)

Current

- 01** 1Arms (Constant, Peak 3Arms)
- 03** 3Arms (Constant, Peak 6Arms)
- 05** 5Arms (Constant, Peak 10Arms)
- 10** 10Arms (Constant, Peak 20Arms)

Feedback Sensor (bit operation)

Bit0	Incremental Encoder	Bit4	Sin/Cos Encoder	Bit8	Potentiometer
Bit1	Dual Incremental Encoder	Bit5	BISS/SSI Interface Encoder	Bit9 ~ Bit15	Reserved
Bit2	Separated Digital Hall Sensor	Bit6	Analog Hall Sensor		
Bit3	Shared Digital Hall Sensor	Bit7	Tamagawa Serial Encoder		

Ex) Incremental Encoder + Shared Digital Hall Sensor + Analog Hall Sensor = 0000 0000 0100 1001 = 0049

Communication

- E** EtherCAT
- C** CAN

Document no. WER-D048/10-FS00FD-C

CONTENTS

Precautions.....	1
Copyright Notice	1
CONTENTS.....	3
1. Technical Information	4
1.1. Mechanical Data	4
1.2. Electrical Data	5
2. Wiring	6
2.1. Tools.....	6
2.2. Connections	6
2.3. Regenerative resistance.....	7
2.4. Main Power	8
2.5. UVW.....	9
2.6. Analog Encoder.....	10
2.7. Biss Encoder.....	11
2.8. Digital Encoder.....	12
2.9. GPIO	13
2.10. EtherCAT.....	15
2.11. CAN.....	16
2.12. RS-485	17
2.13. USB.....	18

1. Technical Information

1.1. Mechanical Data

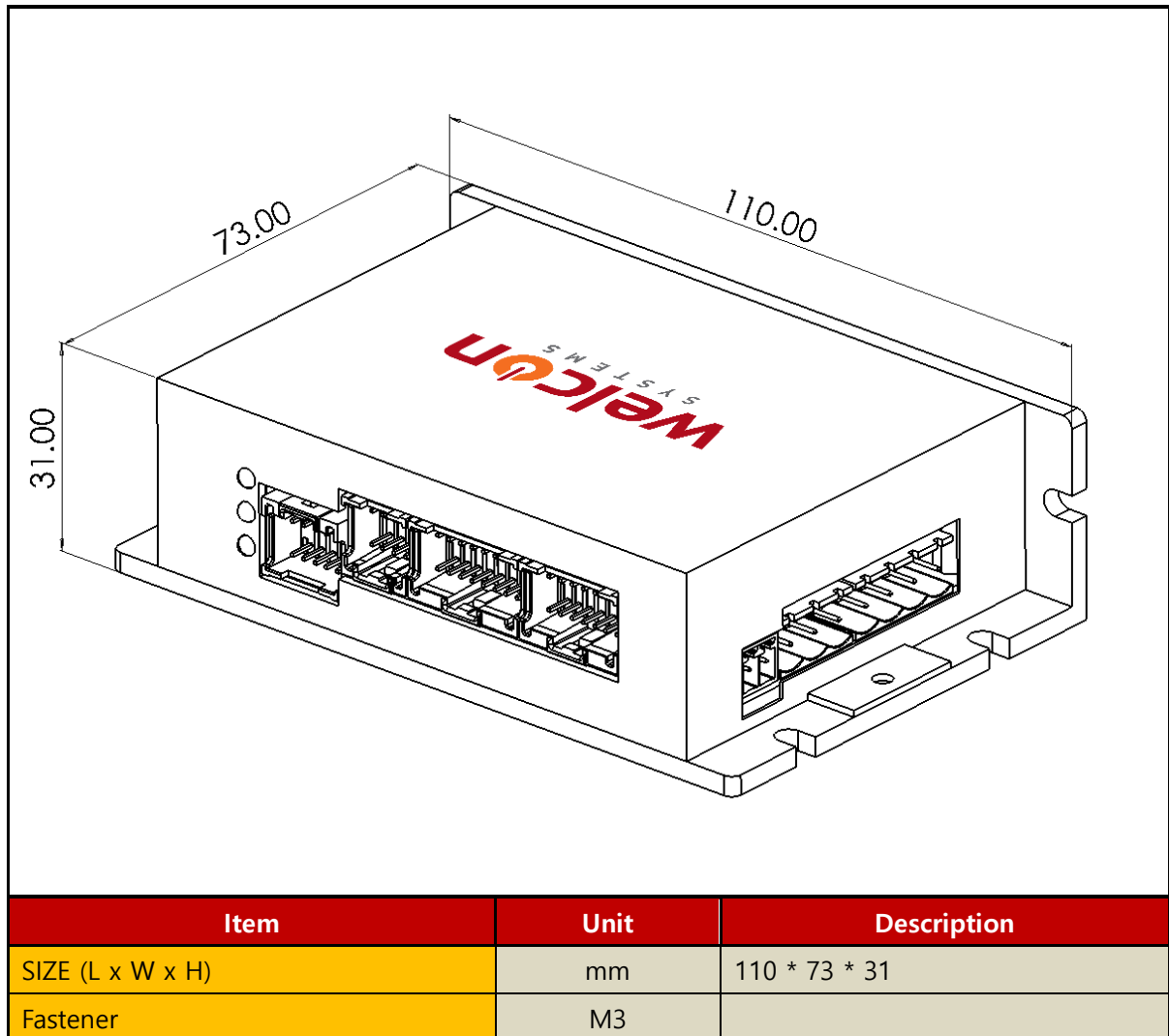

[*For details, please refer to the 3D Modelling on the homepage.](#)

1.2. Electrical Data

WER-D048/10-FS00FD-C			
Basic	Motors	DC/BLDC/PMSM/VCM	
	Communication	USB+CANopen or EtherCAT(CoE, FoE)	
	GUI	WELSS, Setting, Drive, Motor, Feedback, I/O, Motion	
	Position Sensor	Incremental Encoder Shared/Separated Hall Sensor Analog Hall Sensor Sin/Cos Encoder SSI/Biss-C/Tamagawa Serial Encoder	
Inputs & Outputs	Analog Input	Quantity	1
		Voltage Range	Analog ± 10 VDC differential
		Input Resolution	14 bit
	Digital Input	Quantity	6 (with STO)
		Signal	Configurable. Opto-isolated
		Voltage	24V
	Digital Output	Quantity	2
		Signal	Configurable. Opto-isolated. Open collector
		Voltage	24V
		Max. Output Current	50mA
Motor Feedback	General	Supply Voltage	5VDC
	Incremental Encoder	Signal	A-quad-B with or without index, shared digital hall sensor, RS422, Differential
		A-quad-B Max Input Frequency	10MHz (before quadrature)
	Digital Hall Sensor	Signal	Differential-ended
		Type	Separated and shared hall sensor
	Analog Hall Sensor	Signal	0~5V, Single-ended
		Sampling Frequency	24KHz
	Sin/Cos Encoder	Signal	-0.7~+0.7V at 2.5V
		Sampling Frequency	24KHz
	Serial Encoder	Type	SSI, Biss-C, Tamagawa
Bite rate		0.5Mbps, 1Mbps, 2Mbps, 2.5Mbps, 5Mbps	

[*For details, please refer to the specification on the homepage.](#)

2. Wiring

2.1. Tools

Tool	Manufacturer	Part Number
Hand crimp Tool	MOLEX	63811-6300

2.2. Connections

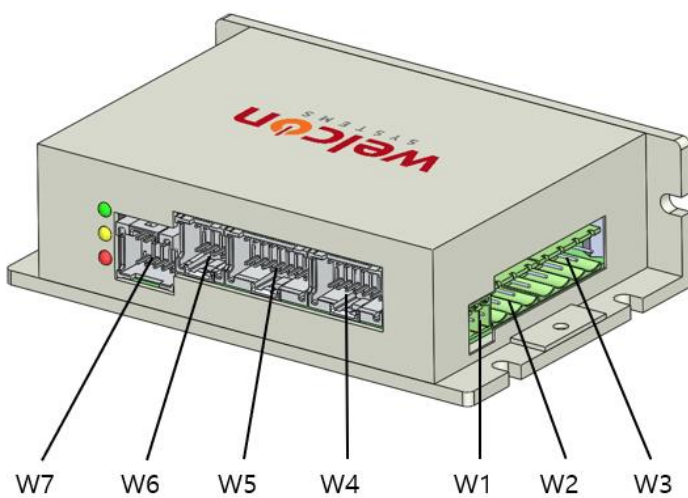

W1 → Regenerative resistance

W2 → Main Power

W3 → Motor Power

W4 → Analog Encoder

W5 → Digital Encoder

W6 → Serial Encoder

W7 → GPIO

W8 → USB

W9 → EtherCAT Output

W10 → EtherCAT Input

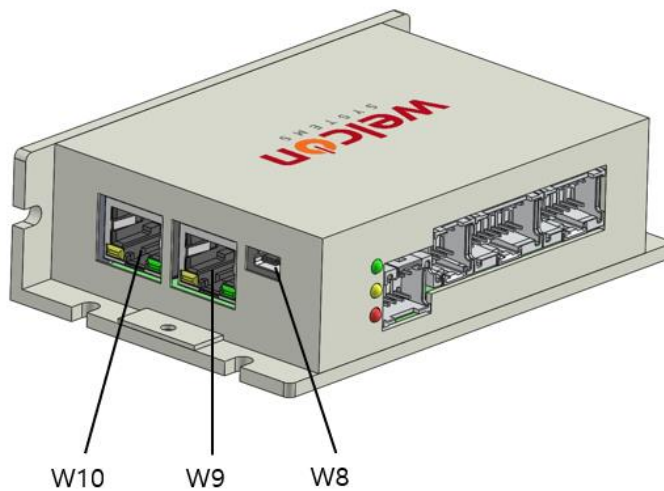

W10

W9

W8

2.3. Regenerative resistance

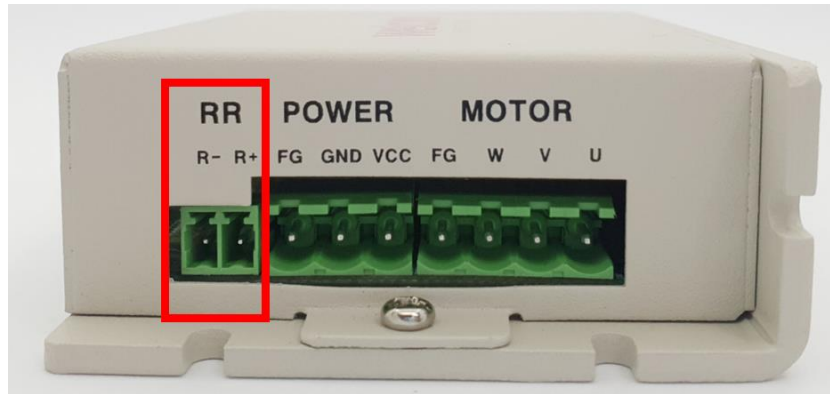

EC350V-2P

ECH350R-02P		J904
Pin	Input Power	
1	R+	
2	R-	

2.4. Main Power

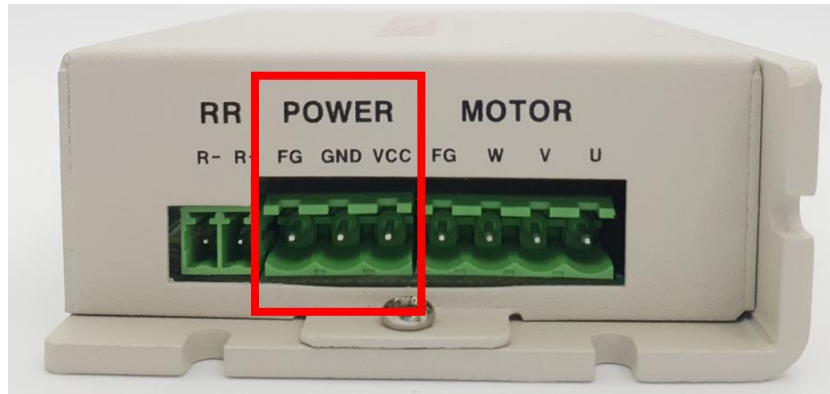

5ESDV 03P

5EHDR-03P		J1
Pin	Signal	Input Power
1	VCC	12V~ 48V DC
2	GND	GND
3	FG	FG

2.5. UVW

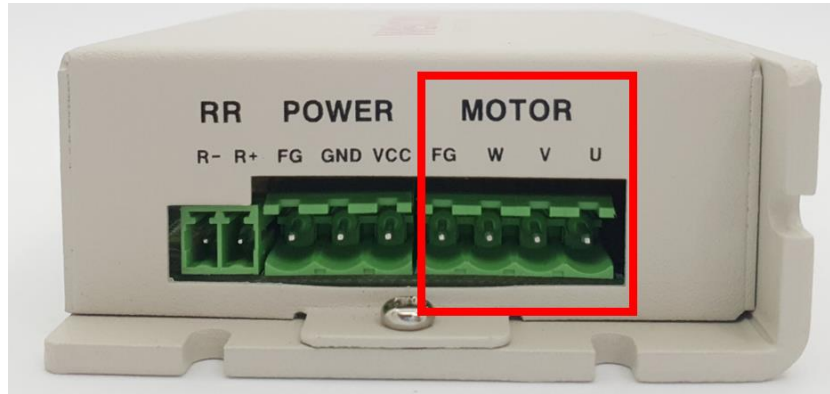

5ESDV 04P

5EHDR-04P		J101
Pin	Signal	
1	U	
2	V	
3	W	
4	FG	

2.6. Analog Encoder

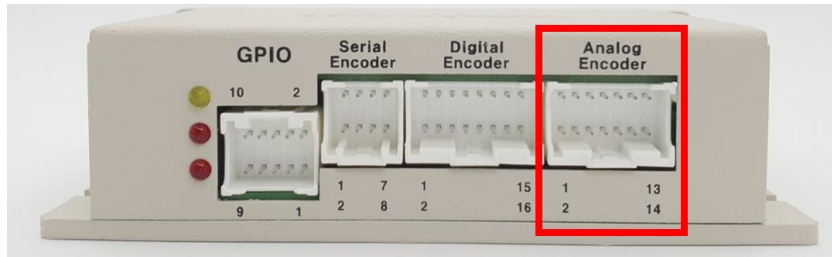

Molex_51353-1400

Molex 561349000



Molex 55959-1430		J901
Pin	Signal	
1	SIN+	
2	SIN-	
3	COS+	
4	COS-	
5	REF+	
6	REF-	
7	5V	
8	GND	
9	FG	
10	AHALL_U	
11	AHALL_V	
12	AHALL_W	
13	AIN+	
14	AIN-	

2.7. Biss Encoder

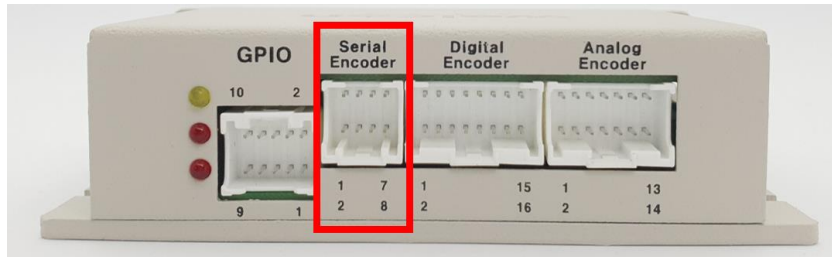

Molex_51353-0800

Molex 561349000



Molex 55959-0830		J801
Pin	Signal	
1	BISS_DATA+ (SLO+)	
2	BISS_DATA- (SLO-)	
3	BISS_CLK+ (MA+)	
4	BISS_CLK- (MA-)	
5	RS485_RTX+	
6	RS485_RTX-	
7	5V	
8	GND	

2.8. Digital Encoder

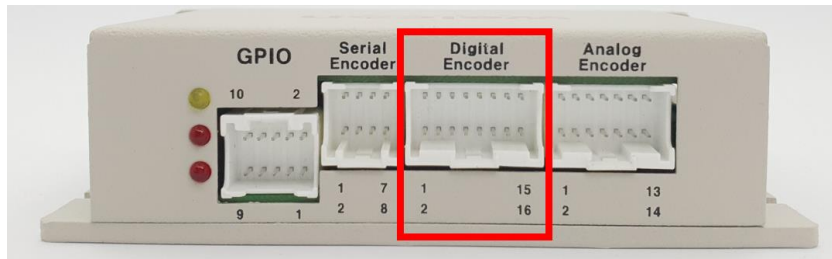

Molex_51353-1600

Molex 561349000



Molex 55959-1630		J701
Pin	Signal	
1	5V	
2	GND	
3	Encoder A+	
4	Encoder A-	
5	Encoder B+	
6	Encoder B-	
7	Encoder I+	
8	Encoder I-	
9	HALL U+	
10	HALL U-	
11	HALL V+	
12	HALL V-	
13	HALL W+	
14	HALL W-	
15	FG	
16	GND	

2.9. GPIO

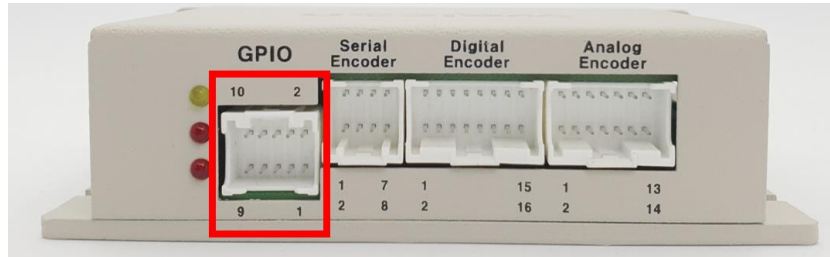

Molex_51353-1000

Molex 561349000



Molex 55959-1030		J301
Pin	Signal	
1	STO	
2	NEGATIVE_LIMIT	
3	POSITIVE_LIMIT	
4	HOME	
5	GPI 0	
6	GPI 1	
7	GPI_COMMON	
8	GPO 0	
9	GPO 1	
10	GPO_COMMON	

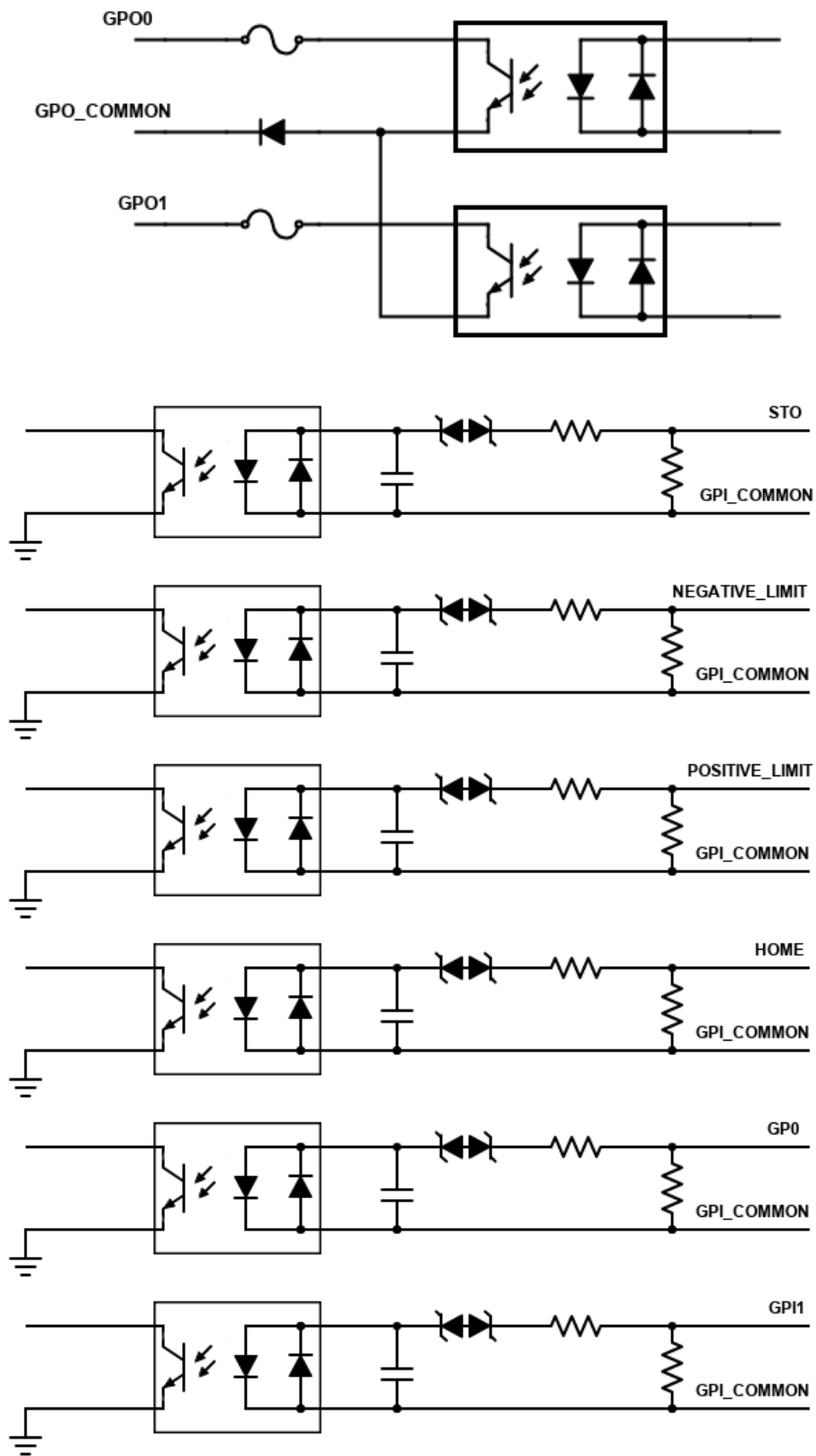

[GPIO Circuit]

2.10. EtherCAT

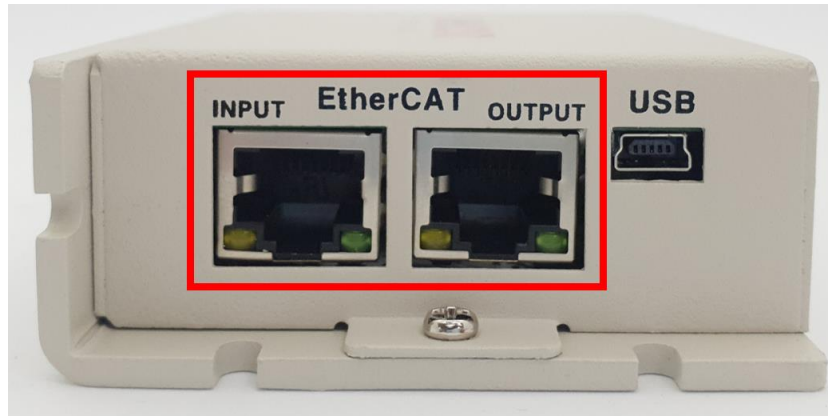

8pin RJ45	
Pin	Signal
1	EtherCAT Tx+
2	EtherCAT Tx-
3	EtherCAT Rx+
4	NC
5	NCs
6	EtherCAT RX-
7	NC
8	NC

2.11. CAN

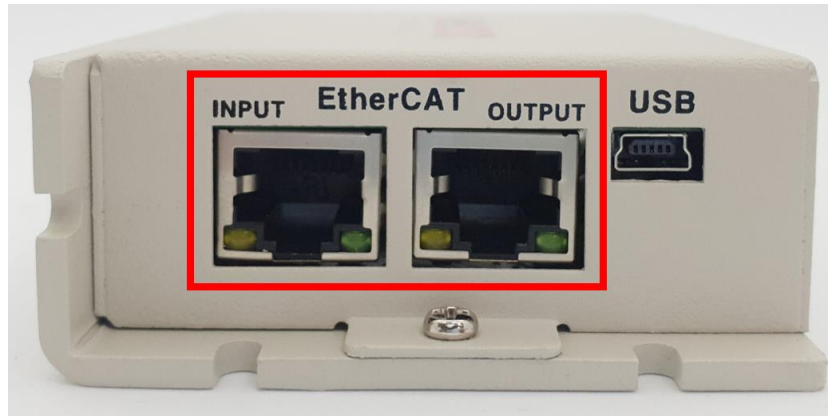

8pin RJ45	
Pin	Signal
1	HIGH
2	LOW
3	GND
4	NC
5	NC
6	NC
7	GND
8	NC

2.12. RS-485

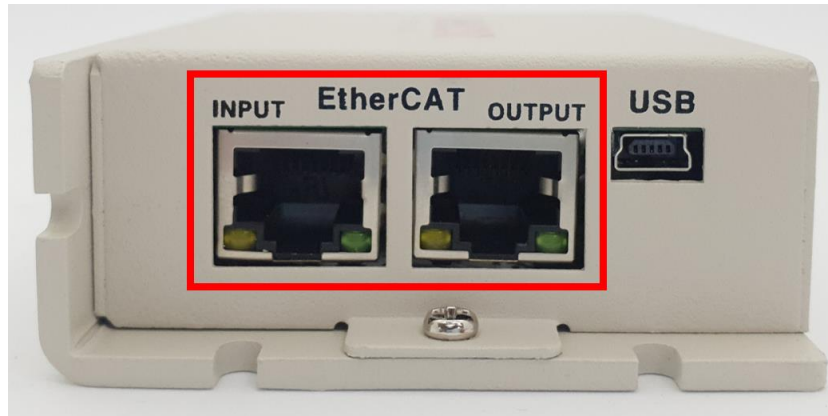

8pin RJ45	
Pin	Signal
1	RTD+
2	NC
3	GND
4	RTD-
5	NC
6	NC
7	NC
8	NC

2.13. USB

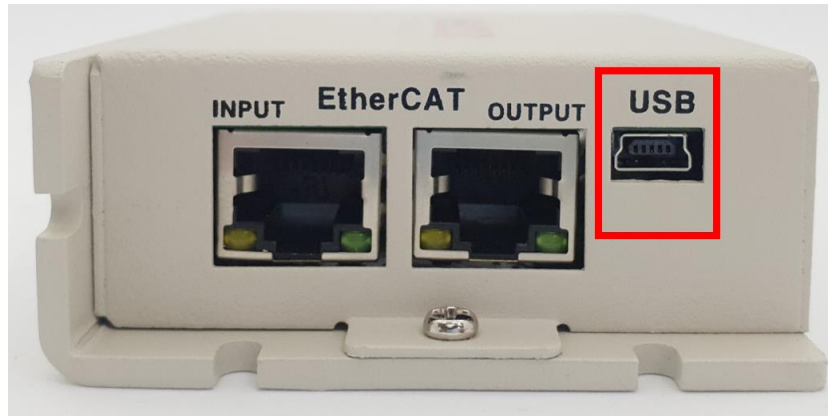

USB-Mini Type B (Keystone Model:937)	
Pin	Signal
1	VBUS
2	DM
3	DP
4	ID
5	GND
6	SHIELD



© 2021 WELCON Systems. All rights reserved.

Copyright in this document is reserved exclusively by WELCON SYSTEMS. That is, the owner of the text, images, and all other materials listed in this document is WELCON SYSTEMS. Therefore, the unauthorized distribution, transfer, or duplication of the text, images, and other materials in this document without the written permission of the copyright holder, WELCON SYSTEMS, is prohibited.

WELCON SYSTEMS

(15588) 143, Hanggaul-ro, Sangrok-gu, Ansan, Gyeonggi-do, Republic of Korea

PHONE +82 31 417 6735

FAX +82 31 417 6736

www.welconsystems.com